

2-JAW PARALLEL GRIPPERS WITH LONG STROKE

HRC-01-102270

▶ PRODUCT SPECIFICATIONS



▶ Gripping force diagram

▶ Forces and moments

Displays static forces and moments that can also have an effect, besides the gripping force.



Mr [Nm]	25
Mx [Nm]	25
My [Nm]	25
Fa [N]	500

▶ TECHNICAL DATA

Order no.	HRC-01-102270
Suitable for robot type	ISO TK 50
HRC design according to ISO/TS 15066	Yes
HRC form	cooperative
Cable management	external
Safety function	STO
Type of drive	electrical
Control	IO-Link
Integrated position sensing	
Stroke per jaw [mm]	40
Stroke per jaw, adjustable [mm]	40
Self locking mechanism	mechanical
Gripping force min. [N]	100
Gripping force max. [N]	
Gripping force in accordance with ISO/TS 15066 [N]*	>140
Nominal gripping force [N]	500
Control time [s]	0.1
Permissible weight per jaw max [kg]	0.3
Length of the gripper fingers max. [mm]	80
Jaw speed in force mode max. [mm/s]	50
Jaw speed in positioning mode max. [mm/s]	60
Repetition accuracy +/- [mm]	0.05
Operating temperature [°C]	5 ... +50
Current consumption max. [A]	7.5
Minimum positioning path per jaw [mm]	3
Protection to IEC 60529	IP40
Weight [kg]	1.6

*Value based on the parameters described in the ISO/TS 15066, determined with a force measuring device certified by the DGUV (German Social Accident Insurance)

▶ TECHNICAL DRAWINGS

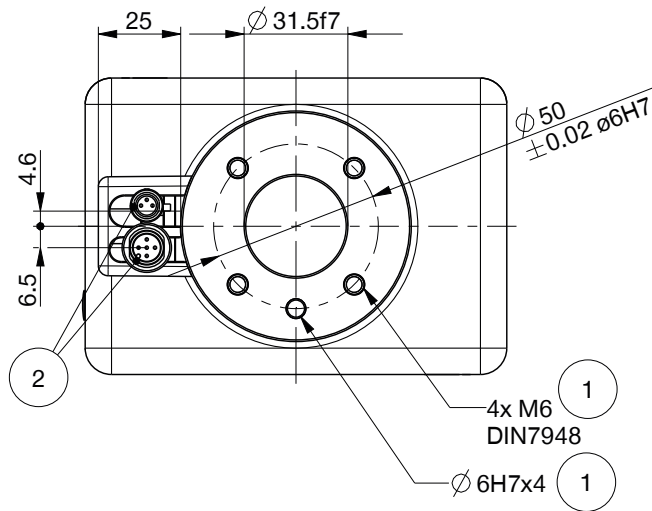

- ① Gripper attachment
- ② Energy supply
- ③ Fixing for gripper finger
- ④ Robot mount

